

HELPMAN
since 1924

Independent supplies

Dual Air Discharge Coolers

LDX

Standard cooler for cold storage & working production areas

Capacities 3.4 - 18.6 kW



Low noise executions

All halogen refrigerants

Easy install



Dual air discharge coolers

LDX



Contents

	page
Model indication.....	2
Eurovent	2
General information.....	3
Options & refrigerant circuiting	4
Fan data & defrost systems.....	5
Correction factors & selection example.....	6
Capacities & technical data	7

Eurovent

Within Europe, a wide variety of published data on capacities are in use, generally depending on national standards. Most in use by the leading manufacturers are national and international standards like DIN, ENV, NEN-EN and ASHRAE. Due to this, customers have not been able to make objective product comparisons, since data published on capacities were based on DT₁, DTM, dry or wet conditions, with or without certification, etc.



To meet the European requirements on EN standards, the European Refrigeration Industry embodied by Eurovent has set standards to guarantee an independent certification procedure for forced convection air cooled condensers based on NEN-EN 327 and unit air coolers based on NEN-EN 328. Being an active member of Eurovent, the capacities of the Helpman commercial cooler programme, as given in the technical documentation, are based on NEN-EN 328 (evaporating temperature $t_0 = -8\text{ }^\circ\text{C}$, 8 K temperature difference between air-on temperature and evaporating temperature (DT₁)).

In order to enable air cooler selection for operating conditions, technical documentation should also give capacities for humid/frosted conditions. According to Eurovent these 'frosted conditions' are to be calculated by multiplying 'dry capacities' with a factor 1.15. These data can be found in the capacity tables, in the columns marked "frosted".

Model indication

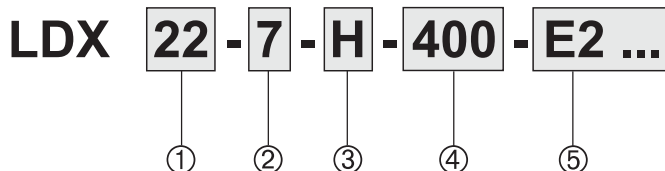

Pos.	Reference	Options
1	Cooler type	14-24
2	Fin spacing	7 mm
3	Fan type	H (n = 1500 rpm) L1 (n = 1000 rpm) L2 (n = 500 rpm)
4	Current	400 = 230/400/50/3 230 = 230/50/1
5	Options	For a full survey of all available options see page 4.

Capacities

Frosted conditions

- Lightly frosted coil.
- Relative humidity 85 %.
- Suction gas superheating 62% of the temperature difference (DT₁), with a minimum of 3.5 K.
- Refrigerant liquid temperature 30 °C (for t₀ = -20 °C and below: liquid temperature 10 °C).

Evaporating temperature t₀

Evaporating temperature t₀ is the saturated temperature according to the pressure at the suction outlet of the cooler.

Dry conditions

Cooling capacity where no condensation or ice build-up occurs on the coil (100% sensible cooling). This condition is used by Eurovent to standardise capacity ratings but should not be used when selecting coolers.

For cooler selection use the columns marked "frosted".

Dual air discharge coolers

LDX

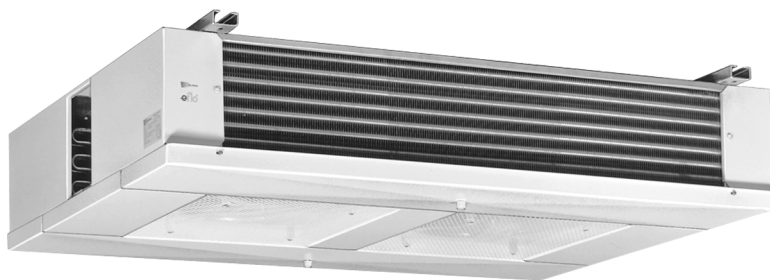

General information

LDX coolers are dual discharge unit coolers for application in cooling and refrigerated working production rooms for the temperature area +5 °C up to -35 °C. The air coolers are suitable for all halocarbon refrigerants. Capacity range (Eurovent SC2) 3.4 to 18.6 kW. Air flow 1700 up to 11600 m³/h.

PED

All coolers and condensers produced by Helpman comply with the Pressure Equipment Directive 97/23/EC. In this respect all equipment is provided with extensive product information. PED certificates may be downloaded from www.helpman.com (standard products only).

Two-Year Guarantee

Because Helpman has the fullest confidence in the product quality, a two-year full guarantee is given.

Other air cooler models

Based upon the same coil configuration as the LDX range Helpman supplies the following air cooler models:

PX

Low silhouette unit coolers
(brochure 50.03)



PLV

Mini air coolers
(brochure 50.04)



LEX

Blow through unit coolers
(brochure 50.02)



LFX

Agricultural storage coolers
(brochure 55.15)



Productconfiguration LDX

- Coil
 - Copper Ripple Fin® tubing ø ½"
 - Tube centres 38 x 38 mm square pitch
 - Aluminium fins
 - Fin spacing 7 mm.
 - Coils are pressure tested with dry air at 36 bar.
- 1 or 2 fans, blowing through the coil, fan diameters 457 or 508 mm. Fan motors protection class IP55.
 - Execution H = 1500 rpm
 - Execution L1 = 1000 rpm
 - Execution L2 = 500 rpm
- Eflo® refrigerant circuiting for higher effective cooling capacity.
- Durable aluminium casing, white epoxy coated (RAL 9003).
- All models fitted with hinged interchangeable and easily removable side plates.
- All models equipped with splash guard.
- Optimized refrigerant circuiting.
- Equipped with a schröder valve on the suction connection for testing purposes.
- Sufficient room for fitting the expansion valve inside.
- Standard suitable for dry expansion (DX system). All models available on request for pumped circulation and glycol.
- Stickers indicate fan direction and refrigerant in/out.
- Heavy duty packing in wooden crates in mounting position. Installation can take place using a forklift.



Dual air discharge coolers

LDX



Options

- **Defrost systems**
 - Electric defrost **E2**
- **Isolating switch (mounted)** **ISM**

Non-standard executions *(on request only)*

- **Defrost systems**
 - Hot gas coil in driptray **G1**

Eflo refrigerant circuiting

The optimal use of the available heat exchanging surface by means of "EFLO" liquid distributions system is based on two principles:



- The refrigerant is evaporating through the coil in parallel flow with the air.
- Superheating takes place on the air-inlet side, in the area with the highest tube temperature.

With Eflo, the cooling performance improves as a result of:

- Even frost formation over the coil.
- Prolongued cooling cycle, therefore a higher effective cooling capacity.
- Shorter defrost cycle.

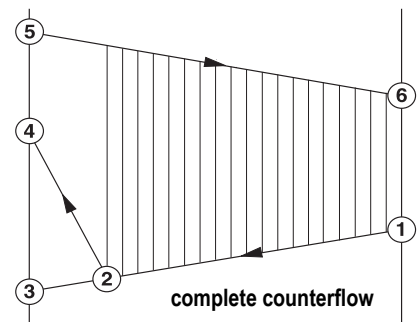
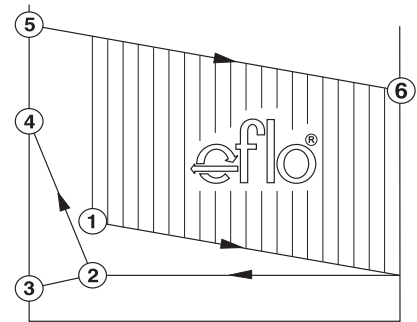

- 1) Refrigerant inlet temperature
- 2) Beginning of superheating refrigerant vapour
- 3) Evaporating temperature (t_0) corresponding with the pressure at the outlet of the cooler
- 4) Superheating temperature
- 5) Air-inlet temperature
- 6) Air-outlet temperature

Dual air discharge coolers

LDX



Defrost Systems

Two forced defrost designs are available for LDX coolers : hot gas defrost and electric defrost. Each defrost system is optimised for specific applications and ambient conditions.

Electric defrost (E2)

Stainless steel heater elements placed in additional tubes between the evaporator tubes. The elements for the driptray are fitted to the bottom of the inner tray.

Both coil and driptray have the same elements. Standard voltage per element 230 V.

Connection to 230 V / 1 phase or 400 V / 3 phase, connected in star with Zero-Wire. Total defrost power is given for 400 V / 3 phase with Zero-Wire.

The elements can be withdrawn at the refrigerant connection side. The driptray elements can be taken out after removal of the outer tray. The heater elements are pre-wired and are connected to one or more terminal boxes.

The following electric defrost system is available for LDX coolers:

E2 *Air on temperature down to - 25 °C.*
Electric stainless steel defrost elements in coil block and driptray.

Defrost power

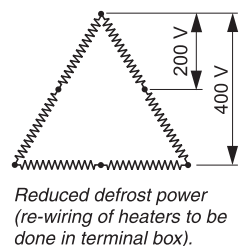
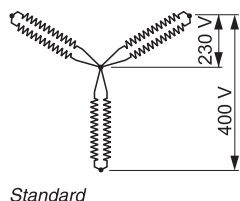

Electrical defrost E2

Cooler-model	number of elements		defrost power kW	
	coil block	driptray	standard	reduced
LDX 14	2 x 2	2 x 1	5.6	4.2
LDX 17	2 x 2	2 x 1	5.6	4.2
LDX 19	2 x 2	2 x 1	11.1	8.3
LDX 22	2 x 2	2 x 1	11.1	8.3
LDX 24	2 x 2	2 x 1	11.1	8.3

Hot Gas Defrost G1 *(on request only)*

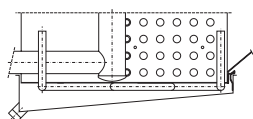

The driptray can be fitted with a copper defrost coil to bring it rapidly up to temperature by means of hot gas. This system may be applied to air on temperatures down to -5 °C.

Fans

Fans mounted in vibration dampers and fitted with balanced aluminium fan blades. Fan guards electrolytically galvanized and epoxy coated according to DIN 31001.

Enclosed design spray-tight motors, protection class IP-55. Motor windings suitable for 230 Volt.

All motors are equipped with a thermal safety device built in the windings, connected to separate terminals in the box.

This safety device can therefore be integrated into the control circuit. The electrical control should be arranged preferably with a manual reset device in order to prevent continuous on/off switching (tripping) of the motors.

Thermal safety device values (A)

Fan motor	LDX type	Temperature °C			
		+10	0	-20	-40
230 / 50 / 1					
220 W	H	2.5	2.6	2.8	2.9
180 W	L1	2.3	2.4	2.6	2.7
35 W	L2	0.6	0.6	0.7	0.7
230 / 400 / 50 / 3					
250 W	H	1.1	1.2	1.3	1.3
250 W	L1	1.1	1.2	1.3	1.3
35 W	L2	0.4	0.4	0.5	0.5

Air throw

The throws as given in the tables are for veiling mounted coolers at t = 20 °C, an unrestrained air flow in the cold room and a minimal air velocity of 0.25 m/s at air throw distance.

Sound pressure dB(A)

Sound pressure as given in the tables are sound pressure levels in dB(A) at 5 m distance in free field conditions. Values may deviate depending on situations at site. The table below gives calculated sound pressure corrections at various distances.

Distance m	Correction dB(A)
1	+ 14
2	+ 8
3	+ 4
4	+ 2
5	0
10	- 6
20	-12
50	-20

Dual air discharge coolers

LDX

Selection Example DT₁

Refrigerant	R-404A dx
Required cooling capacity	7.4 kW
Fan speed	1000 rpm
Air-on temperature	-16 °C
Evaporating temperature	-25 °C

1) $DT_1 = -16 - (-25) = 9 \text{ K}$

2) Correction factor $DT_1/R-404A : 1.06$

3) Multiply required capacity
with correction factor: $7.4 \times 1.06 = 7.8 \text{ kW}$.

4) Cooler models can be selected in the column "capacity/
frosted" on page 7 with a nominal capacity of 7.8 kW.

For the above mentioned conditions the following models can be selected:

- LDX 17-7-L1, nom. cap. 7.1 kW.
- LDX 19-7-L1, nom. cap. 8.5 kW.

Depending on parameters such as *air flow*, *number of fans* and *dimensions* (see tables) a final cooler model selection can take place.

Capacity values under "dry conditions" are reference values for Eurovent conditions.

Standard-condition SC	Air on temp. °C	Evaporating temperature °C	Factor dry/frosted
SC1	10	0	1.35
SC2	0	-8	1.15
SC3	-18	-25	1.05
SC4	-25	-31	1.00

SC 2 : Nominal capacity for cooling design.

Air-on temperature is the air temperature at the intake side of the coil block.

Correction factors

DT ₁ K	Evaporating temperature °C									
	+5	0	-5	-8	-10	-15	-20	-25	-30	-35
R-404A & R-507 dx										
6	1.28	1.32	1.38		1.44	1.51	1.58	1.64	1.69	1.72
7	1.06	1.10	1.15		1.20	1.27	1.33	1.39	1.44	1.48
8	0.89	0.93	0.97	1.00	1.03	1.09	1.15	1.21	1.26	1.29
9	0.77	0.80	0.84		0.89	0.95	1.00	1.06	1.11	1.15
10	0.67	0.70	0.74		0.78	0.83	0.89	0.95	1.00	1.04
11	0.59	0.62	0.65		0.70	0.74	0.80	0.85	0.90	0.94
R-134a dx										
6	1.34	1.42	1.50		1.60	1.71	1.82	1.94		
7	1.11	1.17	1.25		1.34	1.43	1.54	1.64		
8	0.94	0.99	1.06		1.14	1.23	1.32	1.42		
9	0.81	0.86	0.92		0.99	1.07	1.16	1.25		
10	0.70	0.75	0.80		0.87	0.94	1.03	1.11		
11	0.62	0.66	0.71		0.77	0.84	0.92	1.00		
R-22 dx										
6	1.34	1.39	1.45		1.52	1.59	1.66	1.73	1.78	1.81
7	1.11	1.15	1.21		1.27	1.33	1.40	1.47	1.52	1.55
8	0.94	0.98	1.03		1.08	1.14	1.21	1.27	1.32	1.36
9	0.81	0.84	0.89		0.94	1.00	1.06	1.12	1.17	1.21
10	0.70	0.74	0.78		0.82	0.88	0.94	1.00	1.05	1.09
11	0.62	0.65	0.69		0.73	0.78	0.84	0.90	0.95	0.99
R-404A & R-507A pumped system										
6	1.00	1.07	1.13		1.19	1.24	1.29	1.34	1.39	1.44
7	0.82	0.88	0.94		1.00	1.05	1.10	1.15	1.20	1.25
8	0.70	0.75	0.80		0.85	0.90	0.95	1.00	1.05	1.11
9	0.60	0.65	0.69		0.74	0.79	0.84	0.89	0.94	1.00
10	0.52	0.56	0.61		0.65	0.70	0.75	0.80	0.85	0.91
11	0.46	0.50	0.54		0.58	0.62	0.67	0.72	0.78	0.84
R-22 pumped system										
6	1.13	1.21	1.28		1.34	1.39	1.44	1.48	1.53	1.58
7	0.92	0.98	1.05		1.10	1.16	1.21	1.25	1.30	1.36
8	0.76	0.82	0.88		0.93	0.98	1.03	1.08	1.14	1.20
9	0.64	0.70	0.75		0.80	0.85	0.90	0.95	1.01	1.07
10	0.55	0.60	0.65		0.70	0.74	0.79	0.84	0.90	0.97
11	0.48	0.52	0.57		0.61	0.66	0.71	0.76	0.82	0.89

Correction factors for other refrigerants on request.

Dual air discharge coolers

LDX

Capacities & technical data

Cooler model	Capacity R404A / R507A (kW)		Air flow m ³ /h	Coil surface m ²	Int. vol. dm ³	Weight kg	Fans						
	Frosted <i>t</i> ₀ =-8°C DT ₁ =8K	Dry <i>t</i> ₀ =-8°C DT ₁ =8K					Number	Diam. mm	Capacity W nom./absorbed*		Air throw m	Sound pressure dB(A)	Cable inlet
Execution H n = 1500 rpm													
LDX 14-7-H	5.5	4.8	3500	20.9	8.1	58	1	457	220	250	7	60	2 x M20 x 1.5
LDX 17-7-H	9.2	8.0	5800	34.9	13.3	75	1	508	220	250	10	63	2 x M20 x 1.5
LDX 19-7-H	11.1	9.7	7000	41.9	15.8	105	2	457	220	250	10	63	2 x M20 x 1.5
LDX 22-7-H	14.7	12.8	9320	55.9	20.8	122	2	457	220	250	11	63	2 x M20 x 1.5
LDX 24-7-H	18.6	16.2	11600	69.8	28.6	141	2	508	220	250	13	66	2 x M20 x 1.5
Execution L1 n = 1000 rpm													
LDX 14-7-L1	4.2	3.7	2350	20.9	8.1	58	1	457	180	250	5	53	2 x M20 x 1.5
LDX 17-7-L1	7.1	6.2	3900	34.9	13.3	75	1	508	180	250	7	56	2 x M20 x 1.5
LDX 19-7-L1	8.5	7.4	4700	41.9	15.8	105	2	457	180	250	7	56	2 x M20 x 1.5
LDX 22-7-L1	11.2	9.7	6200	55.9	20.8	122	2	457	180	250	8	56	2 x M20 x 1.5
LDX 24-7-L1	14.4	12.5	7800	69.8	28.6	141	2	508	180	250	9	59	2 x M20 x 1.5
Execution L2 n = 500 rpm													
LDX 14-7-L2	3.4	3.0	1700	20.9	8.1	58	1	457	35	35	4	38	2 x M20 x 1.5
LDX 17-7-L2	4.9	4.3	2400	34.9	13.3	75	1	508	35	35	5	41	2 x M20 x 1.5
LDX 19-7-L2	6.8	5.9	3400	41.9	15.8	105	2	457	35	35	5	41	2 x M20 x 1.5
LDX 22-7-L2	8.5	7.4	4200	55.9	20.8	122	2	457	35	35	5	41	2 x M20 x 1.5
LDX 24-7-L2	9.8	8.5	4800	69.8	28.6	141	2	508	35	35	6	44	2 x M20 x 1.5

* Fan power is given per motor. Absorbed fan power is measured with coil face area blocked for 75% and ambient temperature of 20 °C

Dimensions

Cooler type	Dimensions mm				Refrig. conn.	
	A	B	H	K	in O.D.	suction O.D.S.
LDX 14-7-H	1080	790	300	760	½"	28 mm
LDX 17-7-H	1080	790	452	760	⅝"	28 mm
LDX 19-7-H	1840	1550	300	1520	½"	35 mm
LDX 22-7-H	1840	1550	376	1520	⅝"	35 mm
LDX 24-7-H	1840	1550	452	1520	⅝"	42 mm
LDX 14-7-L1	1080	790	300	760	½"	22 mm
LDX 17-7-L1	1080	790	452	760	½"	28 mm
LDX 19-7-L1	1840	1550	300	1520	½"	35 mm
LDX 22-7-L1	1840	1550	376	1520	½"	35 mm
LDX 24-7-L1	1840	1550	452	1520	½"	35 mm
LDX 14-7-L2	1080	790	300	760	½"	22 mm
LDX 17-7-L2	1080	790	452	760	½"	28 mm
LDX 19-7-L2	1840	1550	300	1520	½"	35 mm
LDX 22-7-L2	1840	1550	376	1520	½"	35 mm
LDX 24-7-L2	1840	1550	452	1520	½"	35 mm

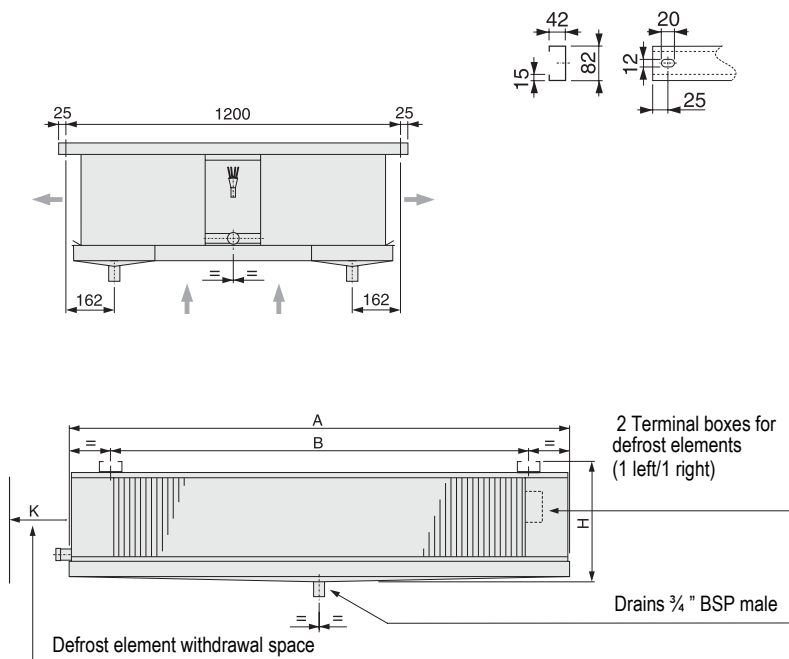

HELPMAN

since 1924

Independent supplier

Helpman BV

PO Box 44

NL-9700 AA Groningen

Tel. ++31 50-5217555

Fax ++31 50-5264878

E-mail info@helpman.com

Internet www.helpman.com

